

MB MINIATURE BEAM LOAD CELL (U.S. & METRIC)

FEATURES & BENEFITS

- Capacities from 5 to 250 lbf (22.2 to 1.11 kN)
- Proprietary Interface temperature compensated strain gages
- Performance to 0.03%
- Low height – 1 in (25.4 mm)
- 0.0008%/°F temp. effect on output

STANDARD CONFIGURATION

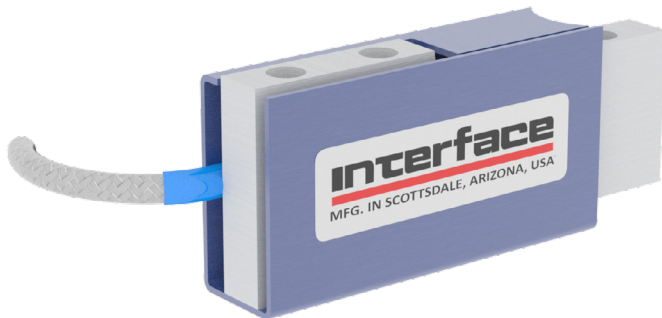

Model MB (Shown)

OPTIONS

- Cable length
- Standardized output
- Custom calibration
- Add connector to cable
- Special temperature range
- Transducer Electronic Data Sheet (TEDS)

CONNECTOR OPTIONS

- 5 ft (1.5 m) integral cable (MB)

ACCESSORIES

- Instrumentation

SPECIFICATIONS

ACCURACY – (MAX ERROR)				
Nonlinearity – %FS		±0.03		
Hysteresis – %FS		±0.02		
Non-repeatability – %RO		±0.01		
Creep, in 20 min – %		±0.025		
TEMPERATURE				
Compensated Range	°F	0 to +150		
	°C	+32 to +65.56		
Operating Range	°F	-65 to +200		
	°C	-53.89 to + 93.33		
Effect on Output – % / °F MAX		±0.0008		
Effect on Zero – %RO / °F MAX		±0.0015		
ELECTRICAL				
Rated Output – mV/V (Nominal)		3.0		
Zero Balance – %RO		±1.0		
Bridge Resistance – Ohm (Nominal)		350		
Excitation Voltage – VDC MAX		15		
Insulation Resistance – Megohm		5000		
MECHANICAL				
Calibration		Compression		
Safe Overload – %CAP		±150		
Material		Aluminum		
NATURAL FREQUENCY/DEFLECTION				
lbf	N	Deflection (in)	Deflection (mm)	Nat. Freq. (Hz)
5	22.2	0.005	0.127	950
10	44.5	0.005	0.127	1300
25	111	0.005	0.127	2250
50	222	0.004	0.102	3300
75	334	0.004	0.102	3900
100	445	0.005	0.127	4000
150	667	0.005	0.127	4750
250	1.11K	0.005	0.127	4400

MB MINIATURE BEAM LOAD CELL (U.S. & METRIC)

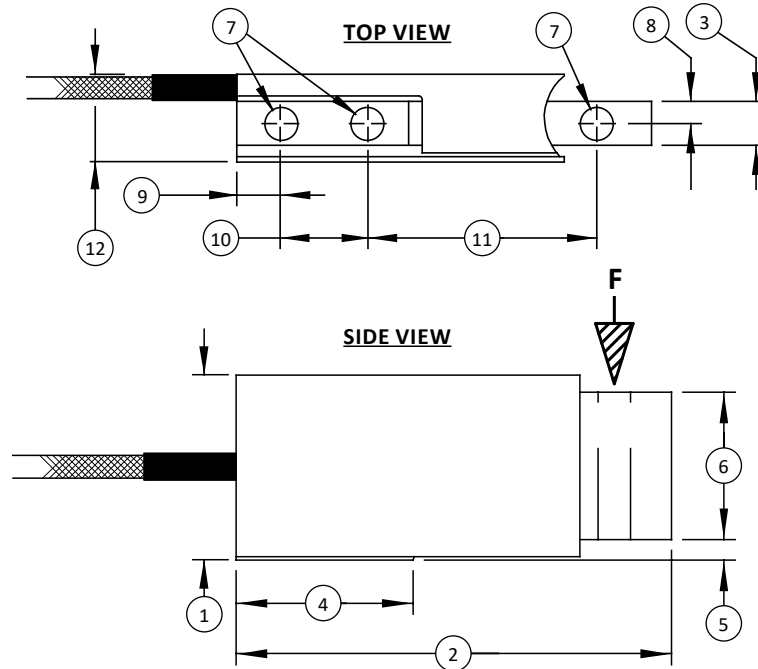

DIMENSIONS

See Drawing	CAPACITY													
	U.S. (lbf)	Metric (kN)	U.S. (lbf)	Metric (kN)	U.S. (lbf)	Metric (kN)	U.S. (lbf)	Metric (kN)	U.S. (lbf)	Metric (kN)	U.S. (lbf)	Metric (kN)	U.S. (lbf)	Metric (kN)
	5, 10	2.22, 44.5	25	111	50	222	75	334	100	445	150	667	250	1.11K
	in	mm	in	mm	in	mm	in	mm	in	mm	in	mm	in	mm
(1)	1.01	25.7	1.01	25.7	1.01	25.7	1.01	25.7	1.01	25.7	1.01	25.7	1.02	25.9
(2)	2.38	60.5	2.38	60.5	2.38	60.5	2.38	60.5	2.38	60.5	2.38	60.5	2.38	60.5
(3)	0.25	6.4	0.25	6.4	0.25	6.4	0.25	6.4	0.25	6.4	0.25	6.4	0.5	12.8
(4)	0.97	24.6	0.97	24.6	0.97	24.6	0.97	24.6	0.97	24.6	0.97	24.6	0.97	24.6
(5)	0.14	3.6	0.11	2.8	0.15	3.8	0.14	3.6	0.13	3.3	0.1	2.5	0.12	3.0
(6)	0.75	19.1	0.81	20.6	0.72	18.3	0.75	19.1	0.78	19.8	0.82	20.8	0.79	20.1
(7)	0.17	4.3	0.17	4.3	0.17	4.3	0.17	4.3	0.17	4.3	0.17	4.3	0.17	4.3
(8)	0.13	3.3	0.13	3.3	0.13	3.3	0.13	3.3	0.13	3.3	0.13	3.3	0.25	6.4
(9)	0.25	6.4	0.25	6.4	0.25	6.4	0.25	6.4	0.25	6.4	0.25	6.4	0.25	6.4
(10)	0.50	12.7	0.50	12.7	0.50	12.7	0.50	12.7	0.50	12.7	0.50	12.7	0.50	12.7
(11)	1.31	33.3	1.31	33.3	1.31	33.3	1.31	33.3	1.31	33.3	1.31	33.3	1.31	33.3
(12)	0.50	12.7	0.50	12.7	0.50	12.7	0.50	12.7	0.50	12.7	0.50	12.7	0.75	19.1

* Metric dimensions and capacities are provided for conversion only. Standard product will be sold in lbf and U.S. dimensions. Metric capacities available upon special request and at an additional cost.